

Type-77 Vacuum Regulator



Precision
Control
Devices

FEATURES

- Single-unit control of pressures from 29" Hg vacuum to 150 psi.
- Flow capacity up to 40 SCFM.
- Dampening action of aspirator tube maintains stable output pressure.
- Output virtually unaffected by changes in supply pressure.
- Can be disassembled and serviced without removing from line.

DESCRIPTION

Bellofram's Type 77 Vacuum Regulator incorporates a fixed negative 15 psig bias spring to maintain vacuum outputs up to 29" Hg. An adjustable opposing range spring increases controlled pressure outputs up to 150 psig.

Output pressure droop under varying downstream flow conditions is minimized by use of an aspirator tube which adjusts the air supply valve opening in accordance with flow velocity. A balanced supply valve, utilizing a reinforced rolling diaphragm, keeps regulator output virtually immune to changes in supply pressure. Stack-up construction makes the Type 77 easily serviceable, without removing it from the air line.

APPLICATIONS

The Type 77 provides precise control in subatmospheric pressure applications. Specific uses include sample collecting systems, air quality monitoring, parts coating operations, and other industrial functions requiring controlled system pressure from 29" Hg vacuum to 150 psig.

The regulator may be installed either upstream or downstream from the vacuum pump. Upstream installation is preferred when rapid evacuation of a vessel or system is required, because the exhaust capacity of the pump is normally greater than that of the regulator. In all other applications, the regulator can be located between the pump and the vessel.

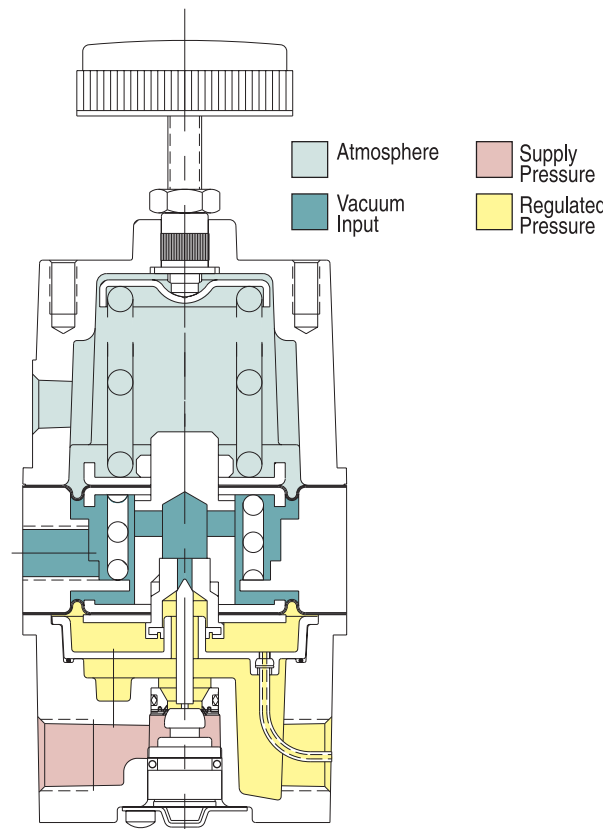

SPECIFICATIONS

Sensitivity	1/2" (1.3 cm) Water Column
Flow Capacity	2.5 SCFM (71 L/M) @ 29" Hg (740 mm Hg) Vacuum ----- 40 SCFM (1130 L/M) @ 100 psig (6.9 BAR) supply, 20 psig (1.4 BAR) output
Effect of Supply Pressure variation (25 psig/1.7 BAR) on Outlet Pressure	Less than 0.1 psig (0.01 BAR)
Max Supply Pressure	250 psig (17.2 BAR)
Ambient Temperature Limits	-40 to 200° F (-40 to 93° C)
Output Pressure Ranges	Vacuum to 2 psig (0.1 BAR) Vacuum to 10 psig (0.7 BAR) Vacuum to 30 psig (2.1 BAR) Vacuum to 100 psig (6.9 BAR) Vacuum to 150 psig (10.3 BAR)
Total Air Consumption @ Maximum Output	6 SCFH (2.8 LPM)
Port Size	1/4" NPT, 3/8" NPT, 1/4" BSPT, 3/8" BSPT
Materials of Construction	Body: Diecast aluminum with vinyl paint Trim: Stainless steel, brass plated steel, Delrin and Buna-N Diaphragm: Buna-N with polyester fabric Knob: Phenolic Plastic Spring: Music wire
Mounting Options	Pipe, Panel or Bracket

PART NUMBERS

T-77	RANGE		PART NUMBER	
	psig	BAR	1/4" NPT Port	3/8" NPT Port
Vac. to	2	0.1	960-500-000	960-505-000
Vac. to	10	0.7	960-501-000	960-506-000
Vac. to	30	2.1	960-502-000	960-507-000
Vac. to	100	6.9	960-503-000	960-508-000
Vac. to	150	10.3	960-504-000	960-509-000

OPTION ORDERING MATRIX

Replace last three digits of part number with digits from table below.

OPTION	5	7	8
5 Epoxy Finish	005	075	085
7 Mounting Bracket		007	087
8 Pressure Gauge			008

To order BSPT threads (including the gauge port) add "BSPT" to end of part number.

CORROSIVE RESISTANT EPOXY FINISH

An epoxy paint applied to the body and bonnet of the regulator exterior surfaces to provide increased corrosion resistance.

MOUNTING BRACKET

Steel (dichromate finish) bracket for side mounting.

PRESSURE GAUGE

Dual scale 2 in. (50.8 mm) gauges. Ranges include 0-30 psig (0-200 kPa), 0-60 psig (0-400 kPa), 0-100 psig (0-700 kPa) and 0-160 psig (0-1100 kPa). When specified with regulator, the correct range will be supplied. For NPT versions only.

DIMENSIONAL DRAWING

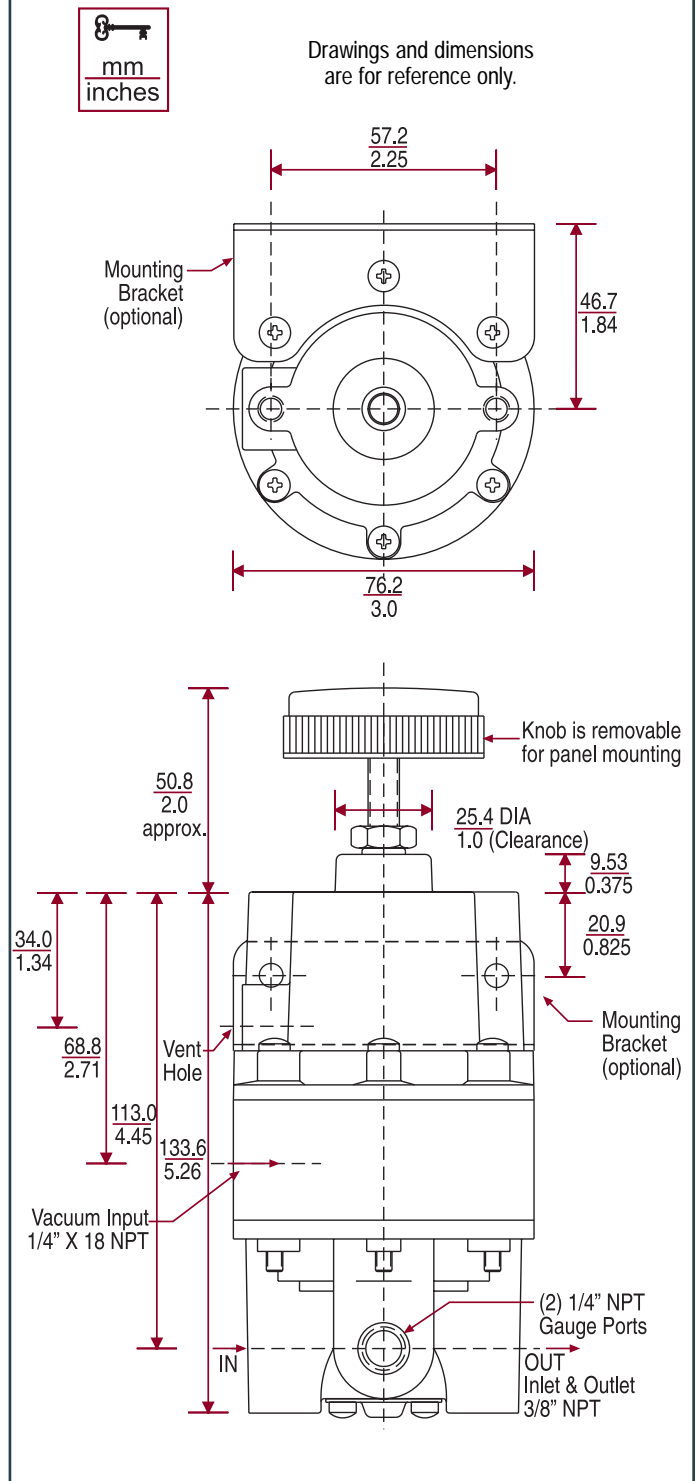

sales@bcgroupintl.com

www.bcgroupintl.com